

# A 4-Channel 28GHz Power Amplifier with 4-Bit Digital Phase Control for 5G RF Front Ends

5G communications promises to offer the user the perception of near infinite capacity. This requires a step change in data rates that will be facilitated by a move to higher transmission frequencies where wider bandwidths are more readily available. New innovative components will be required to meet this demand, such as the 4-channel 28GHz phase adjustable Power Amplifier (PA) described below. Each channel has an output power capability of +30dBm (at 1dB compression) with an IP3 of +38dBm and incorporates independent, 4-bit phase adjustment with an rms phase error of 2.3°.

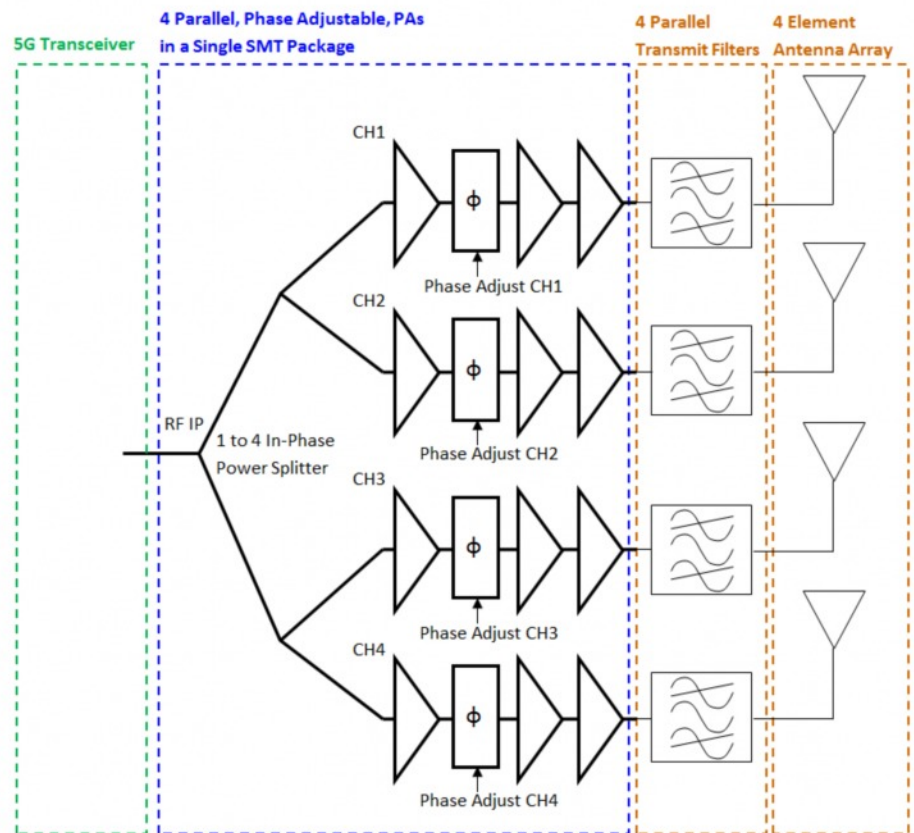


Figure 1: Architecture of the 4-channel transmitter IC

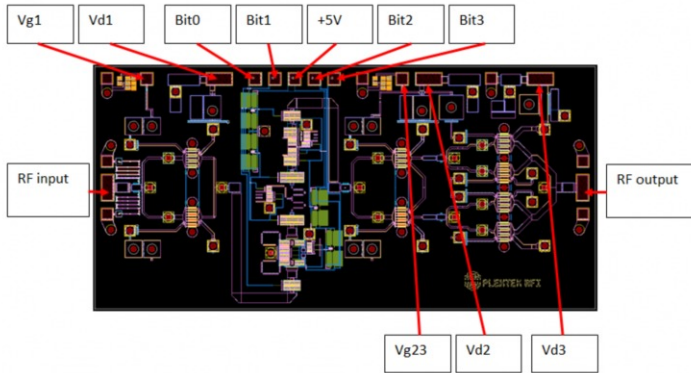
## Introduction

An enormous amount of research effort is currently being devoted to developing 5G technology with the aim of roll out by the year 2020. The details of the 5G standard are yet to be defined, but a common vision for this new standard is that, in addition to providing much higher data rates, it must also allow for extremely low latency (less than one millisecond) and uniform coverage over a wide area. As well as providing improved performance for existing applications, for example allowing the download of several HD movies in a second, the technology will enable and encourage the development of new markets, technologies and applications.

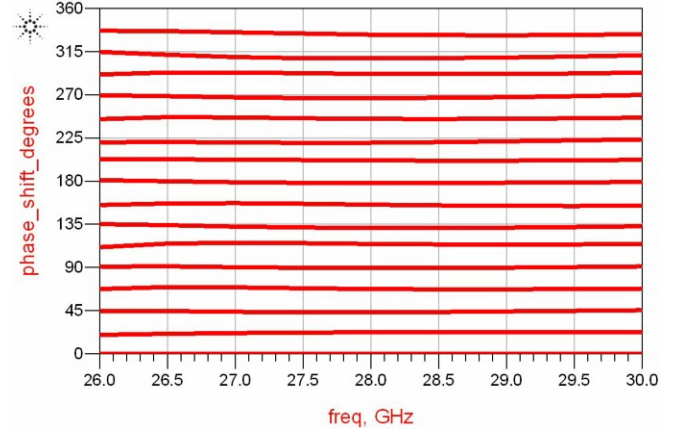
Although there is still much debate about the precise form that 5G will take, there is a degree of consensus that

the standard will require large chunks of contiguous spectrum. This can only be found by utilizing much higher frequencies than the current cellular bands, which operate below 3GHz. Therefore, as well as the use of existing cellular frequency bands, a key component of the new 5G radio interface will be the use of mm-wave frequencies where there is greater spectral availability.

Until recently mm-wave frequencies had been viewed as a rather inappropriate choice for mobile applications due to their unfavourable propagation characteristics. However, recent research, which involved extensive propagation measurements at several mm-wave frequencies around metropolitan areas in both the United States and South Korea, has shown that the



**Figure 2: Layout plot of one channel of the transmitter IC**



**Figure 3: Phase shift versus frequency for a single channel**

issues can be addressed and overcome. Such research included the investigation of more sophisticated antenna schemes employing phased arrays of antennas to optimise the transmitted and received beams at both the base station and the mobile device. Because the wavelengths are small at mm-wave frequencies, this allows such arrays to be incorporated into a small mobile form factor. It also allows the implementation of compact base stations, allowing dense deployment in metropolitan areas. This will be a requirement for 5G systems, both to compensate for the higher attenuation and to allow the highest possible capacity.

The 27.5 to 29.5GHz band is a strong candidate for the new 5G radio interface and much of the research undertaken to date has considered this band.

This white paper describes the design of a 4-channel transmitter IC with each channel containing a PA and an independently controllable 4-bit phase

shifter. The IC is designed using a commercially available 0.15 $\mu$ m GaAs pHEMT process and is intended to be housed in a low cost SMT package suitable for low cost volume production.

### 28GHz 5G Transmit RF Front End Architecture

The architecture of the 28GHz transmit IC is depicted in Figure 1. It interfaces to an array of 4 antenna elements, where each element is driven by one of four parallel phase adjustable power amplifiers. It is likely that some degree of filtering would be implemented immediately after each power amplifier, for harmonic rejection and suppression of receive band noise and unwanted spurious outputs. The inputs to each channel are driven in-phase from a common RF input via a 4-way splitter.

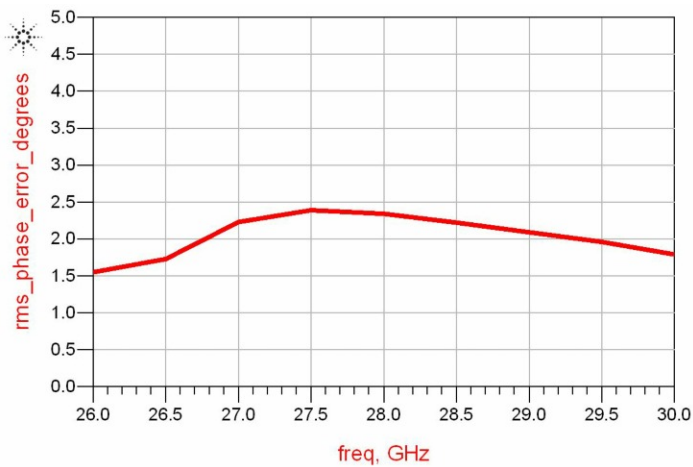
If a particular architecture required a higher number of elements in the antenna array, for example 16, then multiple ICs could simply be used in parallel.

A layout plot of one channel of the transmitter IC is shown in Figure 2. This is a standalone test-chip. The actual transmitter IC itself comprises 4 separate channels with an in-phase splitter at the input. The test chip measures 3.8mm x 1.84mm. The drain supplies for the power amplifier are Vd1, Vd2 and Vd3, and they are nominally set to +6V. Vg1 sets the quiescent bias current in the first stage, and Vg23 sets the quiescent bias current in the second and third stages.

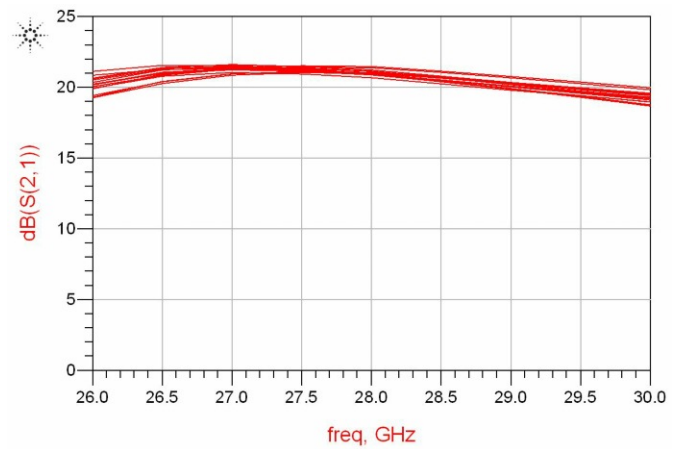
The phase state of each bit of the integrated phase shifter is controlled by a single-ended TTL compatible control line. All logic to shift the levels to those required for the phase shifter bits is included on-chip.

### Single Channel Performance

The 4-bit phase shifter allows the insertion phase of each channel to be set with 22.5° resolution. A plot showing simulated phase shifts versus frequency for each of the 16 states is shown in Figure 3. A flat phase versus



**Figure 4: RMS phase shift error versus frequency for a single channel**



**Figure 5: Gain versus frequency for a single channel, all phase states**

frequency response is clearly evident across the 26 to 30GHz frequency range.

With all phase shifters, there is a deviation from the desired phase state which is dependent on both frequency and the phase setting. The rms phase error is a metric that indicates the phase setting accuracy across all phase states. Figure 4 shows the simulated rms phase error versus frequency for each channel. The worst case rms phase error is 2.38°, occurring at around 27.5GHz.

Each channel of the transmitter IC has a nominal gain of just over 20dB (excluding the splitting losses of the 4-way in-phase splitter). Figure 5 shows the gain versus frequency response for each of the 16 phase states: at 28GHz the gain variation with phase state is  $\pm 0.6$ dB. The total gain variation across both the frequency range (26 to 30GHz) and all phase states is  $\pm 1.5$ dB.

As the phase state of the phase shifter changes the reflected waves from each

bit experience different phase shifts. Sometimes the reflected waves add constructively, thus degrading return loss at the input, and sometimes they add destructively, improving return loss at the input. All multi-bit phase shifters tend to exhibit significant variation in return loss with phase state. The input and output return losses versus frequency are plotted for a single channel in all phase states in Figure 6. Although significant variation in return loss is evident, it remains good across all phase states. At 26GHz, which is the worst case, return loss is 13.4dB at the input and 14.9dB at the output.

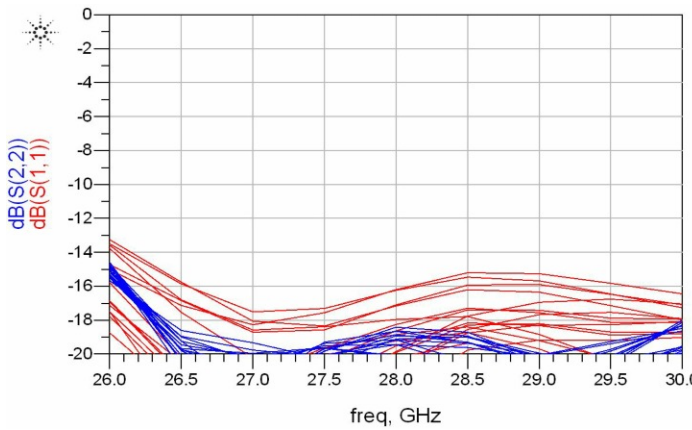
The quiescent bias current of the PA is 62mA from +6V, which provides an RF output power at 1dB gain compression (P-1dB) of 30dBm at 28GHz. The output power (at P-1dB) versus frequency is plotted in Figure 7 for the 0° (reference) phase state. It is nominally +29.5dBm with a variation of  $< \pm 1$ dB across the 26 to 30GHz band.

The corresponding Power Added Efficiency (PAE) for one PA channel oper-

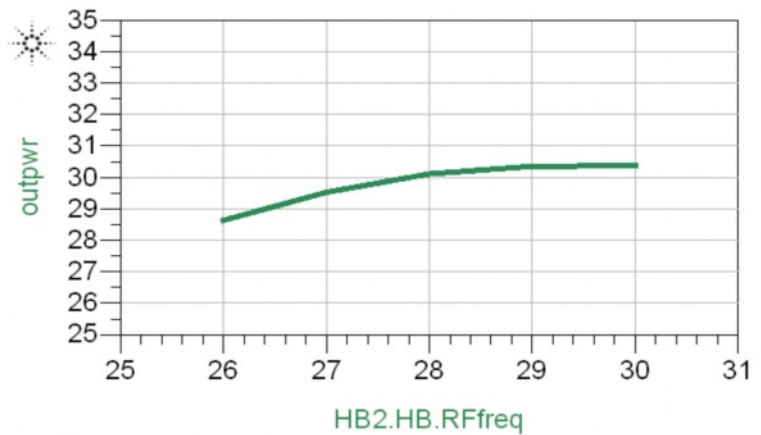
ating at 1dB gain compression is shown in Figure 8. At 28GHz the PAE is 24%, while across the 26 to 30GHz frequency band it is nominally 21.5% with  $\pm 3\%$  variation. 5G systems will operate with modulation schemes having high peak to average power levels. It is therefore likely that the PA will be operated backed off from P1dB at a lower average output power level, in order to preserve modulation fidelity.

The traditional metric for the linearity of microwave amplifiers is the output referred third order intercept point (OIP3). This parameter is plotted against frequency in Figure 9 for the 0° relative phase shift state. In this simulation the total average input power is set to 0dBm i.e. the power in each input tone is -3dBm and the nominal power in each output tone is around +17dBm. The simulated OIP3 is +38.8dBm  $\pm 0.7$ dB across the band.

A summary of the simulated performance of each channel of the phase adjustable PA is presented in Table 1.



**Figure 6: Input and output match versus frequency for a single channel, all phase states**



**Figure 7: P-1dB versus frequency for a single channel, reference phase state**

### Simulations of a Four-Channel Array

Simulations were undertaken to show the antenna pattern produced by a linear array of four omnidirectional (0dB gain) antennas driven by the four channels of the phase adjustable PA MMIC. The antenna spacing was a half wavelength ( $\lambda/2$ ) at 28GHz. The results are presented in Figures 10 and 11, in the form of polar plots showing the normalised antenna responses in dB versus azimuth angle in degrees. The plots include the effects of the systematic gain and phase errors in each channel.

Figure 10 shows the bore-site pattern when the relative phase shift in each channel is set to 0°.

The direction of the main antenna beam can be steered by appropriate adjustment of the insertion phase of each PA channel. Figure 11 shows the simulated antenna pattern when the beam is steered to -38.68°. This is achieved by applying an incremental phase shift of -112.5° per element.

### Conclusions

This white paper describes the design of a 4-channel 28GHz, power amplifier MMIC with independent 4-bit digital phase control available in each channel. It is intended for use in the transmit chain of a 5G RF front-end module in either a mobile device or a base station. It has been designed using a commercially available 0.15 $\mu$ m GaAs pHEMT process, and is suitable for assembly into a single low cost SMT package.

Details of the layout of a test chip for evaluating the performance of a single channel were presented along, with simulation results of key performance parameters including rms phase error, and OIP3. Antenna pattern simulations for four channels driving four elements in a linear array were also given, showing the potential for beam steering using the 4-channel MMIC.

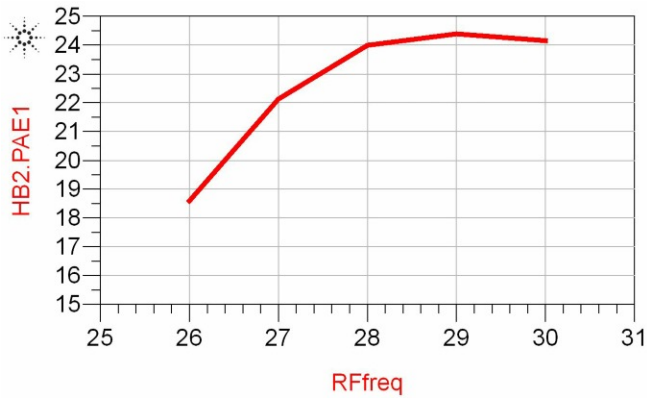
It was noted that although this white paper has focused on a four-element array, the solution can be extended to larger antenna arrays. For example, if

Parameter	Min	Max	Units
Frequency Range	26	30	GHz
RMS Phase Error		2.38	°
RMS Amplitude Error		0.53	dB
Gain	18.5	21.5	dB
Min Output Return Loss	14.9		dB
Min Input Return Loss	13.4		dB
P1dB at 0°	28.5	30.5	dBm
PAE at P1dB at 0°	18.5	24.5	%
OIP3 at 0°	38.1	39.5	dBm

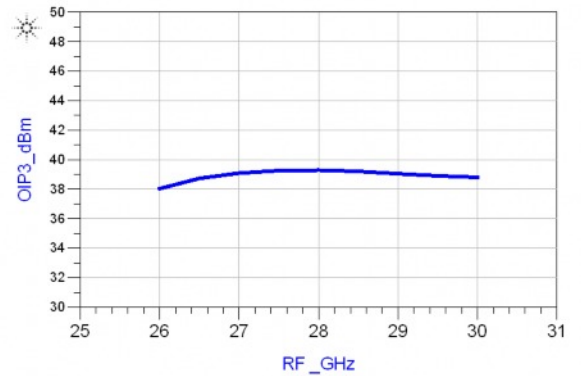
**Table 1: Performance summary of each channel of the 4-channel phase adjustable PA**

the number of elements in the antenna array were 16, then this would require the use of four of the 4-channel phase adjustable power amplifiers in parallel.

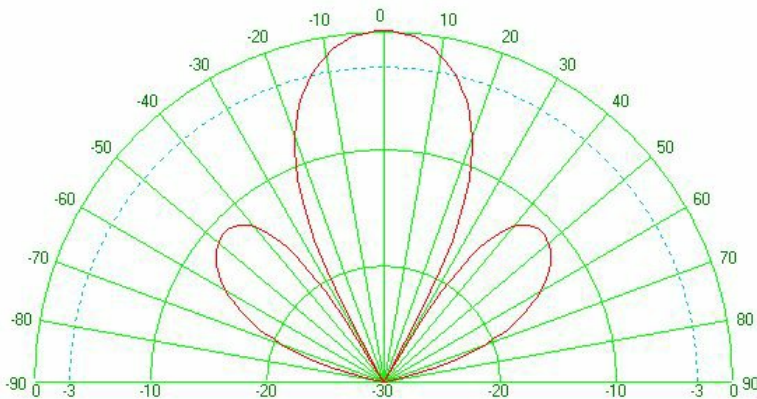




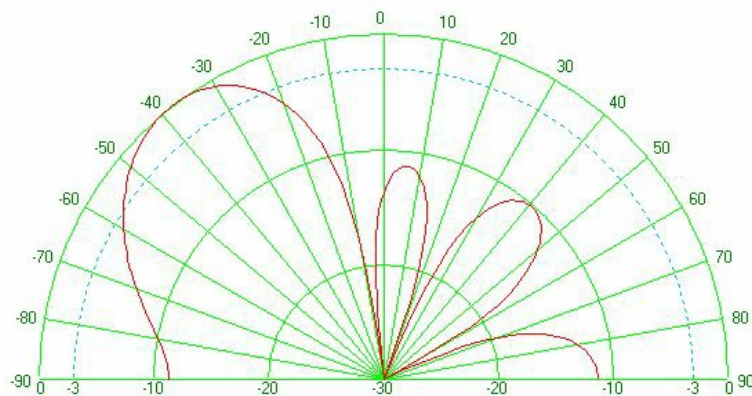
**Figure 8: PAE versus frequency for a single channel at P-1dB, reference**



**Figure 9: Output referred IP3 versus frequency for a single**



**Figure 10: Beam pattern produced with all channels set to the 0° reference state**



**Figure 11: Beam pattern produced with phase states of the four channels set to steer the beam to -38°**